



## No Hoods? No Vents? No Problem!

*A fast bake oven delivering big results.*



**Ventless Operation** – The MultiChef XLT high speed oven is equipped with its own **internal ventilation system**, so you'll save money as there is no need to install any costly vents or hoods to operate. With **high profit margins and short cook times**, this high-speed oven can provide a quick return on your investment.



**Ease of Use** – MultiChef XLT is extremely simple to use and clean, regardless of your kitchen knowledge level. With its **two step cooking system**, every menu item is just a few taps away! Plus with its **unique removable catalytic converter**, cleaning a high speed oven has never been easier.



**Digital Touchscreen** – Your menu has never been so easy to execute. The unique software can display and function in multiple languages, hold up to 1024 recipes, and is organized with imagery making it effortless to operate in a fast-paced kitchen. The **intuitive technology** is key in the performance and functionality to cook, bake, and reheat efficiently.



**Rapid Bake Technology** – MultiChef XLT uses **convection, rapid impinged air, bottom infrared, and precision microwave** to reduce cook times. MultiChef XLT transforms your business into a food preparation powerhouse and **cuts cook times by more than 80% with superior results.**

# MultiChef XLT™ SPECIFICATIONS

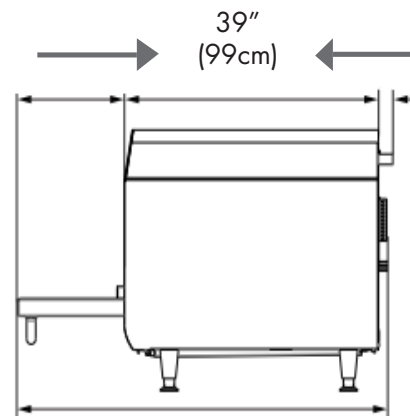
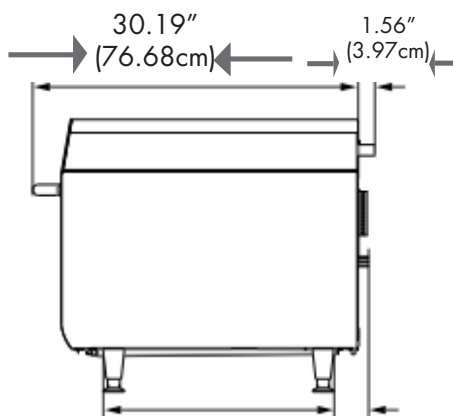
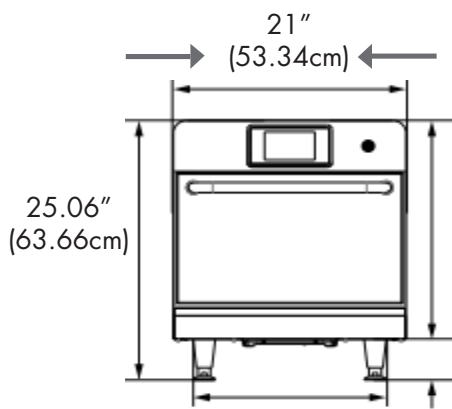



## FRONT VIEW

## SIDE VIEW

### CAPACITY

External Dimensions	21" Wide x 31.75" Deep x 25.06" High (53.34cm Wide x 80.65cm Deep x 63.66cm High)
Internal Dimensions	15.5" Wide x 14.33" Deep x 5.75" High (39.37cm Wide x 36.4cm Deep x 14.6cm High)
Approximate Unit Weight	194 lbs. (88 kg)

### ELECTRICAL

	North America		International
Voltage	208 V	240 V	230 V
Phase	Single	Single	Single
Frequency (Hz)	60	60	50
Power	6.2kW	7.2kW	6.9kW
Circuit Required	16A	16A	30A
Plug Type	NEMA 6-30P (US) 		32 Amp (2P + T) 
Cord Length	6' (1.83m) Cord		
Cooking Temperature Range	86° - 530° F (30° - 276° C)		
Clearances	0" Left Side, 0" Right Side, 3" Back (7.6 cm)		

**ACCESSORIES INCLUDED:** Pizza Peel, Panini Style Grill Plate, Solid Teflon Basket, and USB Drive with pre-programmed recipes.

### SHIPPING

Approximate Crated Weight	242 lbs. (110 kg)
Approximate Shipping Crate Size	22" Wide x 33.86" Deep x 31.5" High (55.8cm Wide x 86cm Deep x 80cm High)



### WARRANTY

1 Year Parts/Labor

### NOTES

We reserve the right to change specifications appearing upon this brochure without notice and without incurring any obligation for the equipment.

Rev 09/2022



Your Source for Ventless  
Kitchen Solutions



www.MultiChef.com  
www.MTIproducts.com



P: 800-348-2976  
P: 508-460-9800  
F: 508-393-5718



1 Bonazzoli Ave  
Hudson, MA 01749 USA